

Lauren



Design: **STUDIO DR**

Lauren

B-21

CONFIGURATIONS

QUEEN • EASTERN OR CALIFORNIA KING

*Top view shown at 1/4" scale.

SPECIFICATIONS

FRAME: Welded tubular steel, powder epoxy coated, select hardwood and industrial grade plywood covered with polyurethane foam and polyester fiber.

SUSPENSION: Beech wood slats.

CUSHIONS: Back rest; multiple density and IFD polyurethane foam wrapped with polyester fiber, quilted and button tufted.

UPHOLSTERY: Fabrics; all edges are serged and top stitched.
Leather; top stitched.

LEGS: Available in black or silver finish.

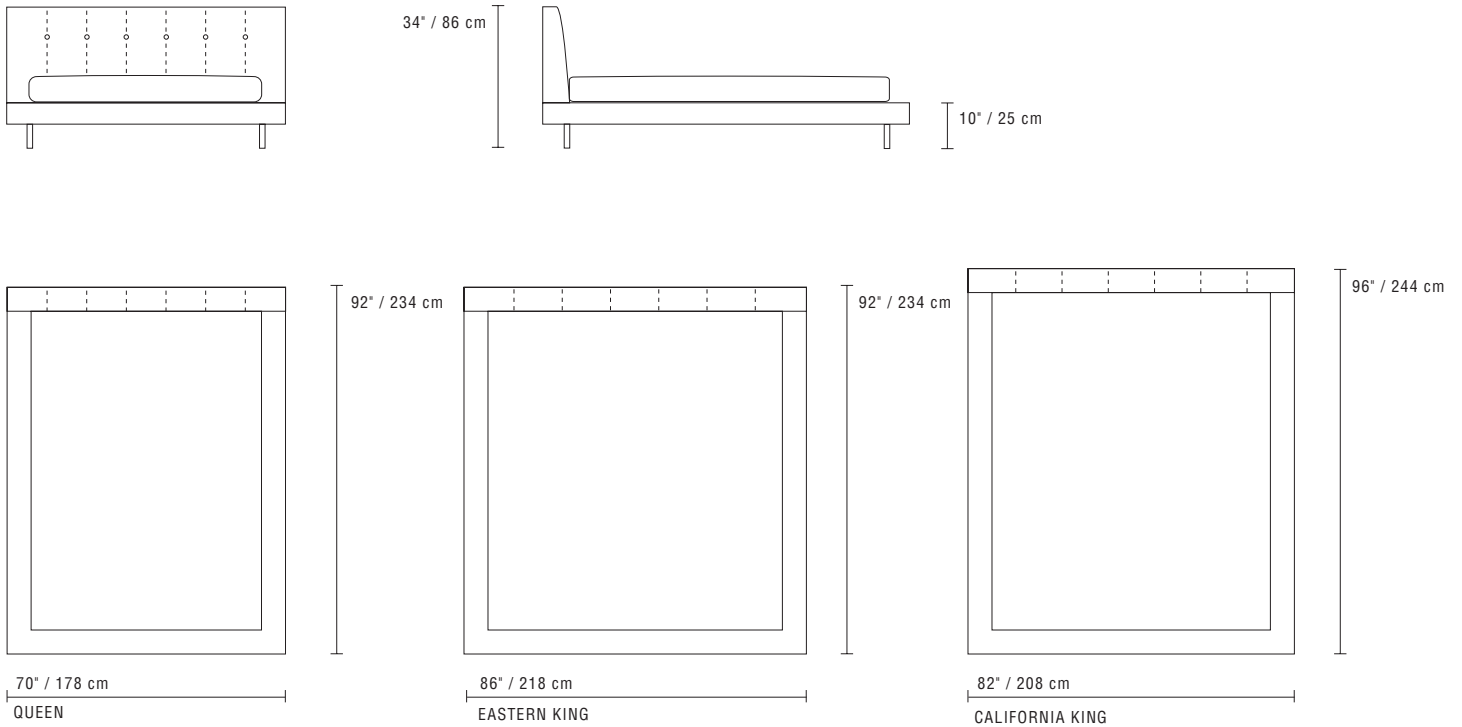

Specifications are subject to change without notice.

©2002 Dellarobbia, Inc.

DELLAROBBI[®]
CALIFORNIA